

A1.3.3 Digital AES/EBU Audio Interfaces

MAGIC THipPro provides eight digital Audio inputs and outputs available on four physical AES/EBU interfaces.

Two 15-pin Sub-D sockets provide the digital AES/EBU interfaces. The BNC socket CLOCK 1 can be used to insert an external AES/EBU clock or to receive an AES/EBU clock . The CLOCK 2 interface is not in use.

As an option adapter cables with XLR connectors can be provided. The pin assignment of the 15-pin Sub-D sockets are shown in TAB. 8. The pin assignment of the BNC socket is described in TAB. 9.



TAB. 8 DIGITAL AUDIO INTERFACES AES/EBU 1-2 AND AES/EBU 3-4

Socket: SUB-D 15 pin

Pin	Signal	Description
1	AES 1 IN +	
2	AES 1 IN -	
3	AES 2 IN +	
4	AES 2 IN -	
5	AES 1 OUT +	
6	AES 1 OUT -	
7	AES 2 OUT +	
8	AES 2 OUT -	
9	GND	
10 ... 15	GND	



Use **WHITE JACKET** CAT5 on 'Digital AES 1-2' & 'Digital AES 3-4' for sub D 1-1 & 2-1.

Use **BLUE JACKET** CAT5 on 'Digital AES 1-2' and 'Digital AES 3-4' for sub D '1-2' & '2-2'.



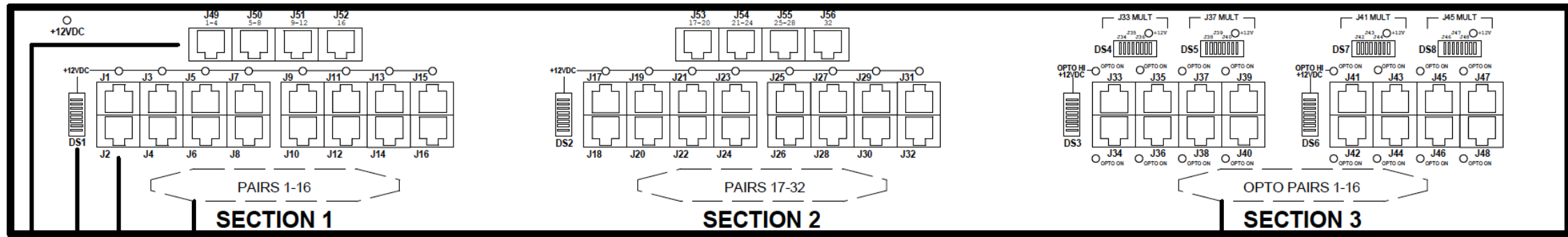

SECTION 1 RJ21 supplies PAIRS 1-16
(Mounted on backside)

SECTION 1 description applies
also to SECTION 2 PAIRS 17-32

SECTION 3 RJ21 supplies OPTO PAIRS 1-16
(Mounted on backside)

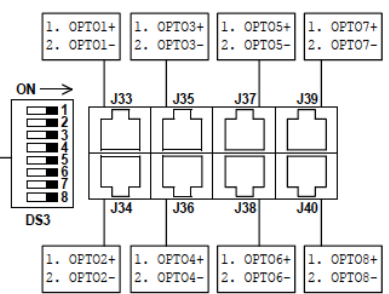
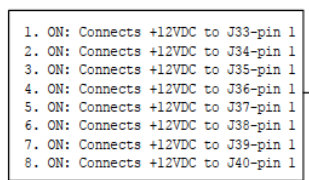
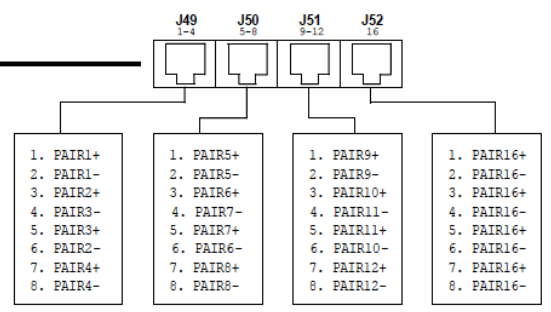
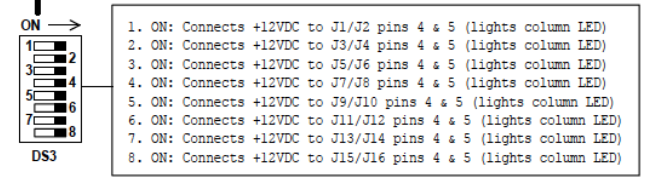
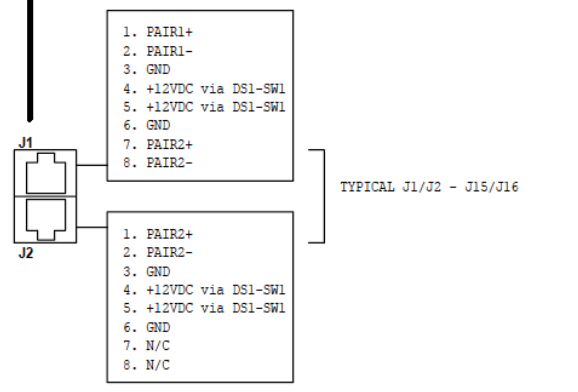

MULT FUNCTION

The MULTI function provides identical connectivity for a group of four RJ45s. Up to four groups are available:

- 1) J33-J36
- 2) J37-J40
- 3) J41-J44
- 4) J45-J48

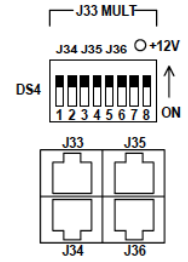

The DIP Switch above a group controls connectivity for pins 1 & 2 and provides the option to connect the group's pins 4 & 5 to +12VDC. Using J33-J36 as an example:

- 1) DS4-SW1,2 = ON ON: Connects J33-pins 1,2 to J34-pins 1,2, respectively.
 - 2) DS4-SW3,4 = ON ON: Connects J33-pins 1,2 to J35-pins 1,2, respectively.
 - 3) DS4-SW5,6 = ON ON: Connects J33-pins 1,2 to J36-pins 1,2, respectively.
 - 4) DS4-SW7,8 = ON ON: Connects pins 4,5 (of J33-J36) to +12VDC and lights LED above DS4.
- Note: With DS4-SW7,8 = OFF OFF, J33-J36 pins 4 & 5 are all still connected together, but not connected to +12VDC.

- The remaining pins of a group are connected as follows:
- 5) Pins 3 & 6 are hardwired to GND.
 - 6) All pin 7's of a group are hardwired together.
 - 7) All pin 8's of a group are hardwired together.

IMPORTANT: When using MULTI function, keep associated OPTO function DIP switches (DS3 and/or DS6) in OFF position.

OPTO FUNCTION

OPTO PAIRS 1-8 are assigned to J33-J40 as shown at left.

- To energize an OPTO:
- 1) Slide corresponding DIP switch to ON position, which applies +12VDC to pin 1 (OPTO+)
 - 2) Connect pin 2 (OPTO-) to pin 3 and/or 6, which are GND (i.e. via relay)
 - 3) Adjacent "OPTO ON" LED indicates OPTO is energized.

If desired, +12VDC can be connected to pins 4, 5 using DS4,5,7,8-SW7,8 as described in MULT section above.

Otherwise, DS4,5,7,8-SW1,2,3,4,5,6 must be in OFF position.

J33-J40/DS3 description applies also to J41-48/DS6 section OPTO PAIRS 9-16

Sierra Automated Systems & Engineering Corp.
2625 San Fernando Blvd.
Burbank, California 91504

Title: **RM2116X3 Panel Description**

Size B	Document Number	Rev A
Date: Monday, June 16, 2008	Sheet 1 of 1	